

World's slimmest diaphragm-isolated solenoid valve (*) KV Series



Features

1 . 6mm Slim Design

This small valve enables you to reduce not only the installation space but also internal pipe length of your manifold by making it possible to mount at 6mm intervals.

2 . Capacity for Bilateral Connection

Easy to make manifolds (see page 3)

3 . Small Internal Volume

Only 10 micro liters (each port)

4 . Excellent Chemical Resistance

PEEK molded body and Perfluoroelastomer diaphragm

TAKASAGO ELECTRIC, INC.

66 KAKITUBATA NARUMI-CHO, MIDORI-KU, NAGOYA, 458-8522 JAPAN

Tel +81-52-891-2301 Fax+81-52-891-7386

E-mail: info@takasago-elec.co.jp URL: <http://www.takasago-elec.co.jp/>

Specifications

Model Number	KV-2-NCG	
Type	2-way Normally Closed	
Orifice Diameter	0.8mm	
Port Connection	O-ring Seal	
Operating Pressure	Inlet: 0 - 100kPa Outlet: 0 - 50kPa	
Fluid Temp. Range	0 – 50 degrees C	
Ambient Temp. Range	0 – 40 degrees C	
Rated Voltage	12 or 24VDC	
Power Consumption	1.8W	
Duty Cycle	Continuous Duty	
Coil Temperature Increase	Max. 90 degrees C From Room Temperature	
Internal Volume	Inlet: 10 micro liters Outlet: 10 micro liters	
Insulation Class	Class B	
Dielectric Strength	1500VAC for 60s	
Weight	8g	
Wetted Materials	Diaphragm	Perfluoroelastomer
	O-ring	Perfluoroelastomer
	Body	PEEK (poly ether ether ketone)

Dimensions

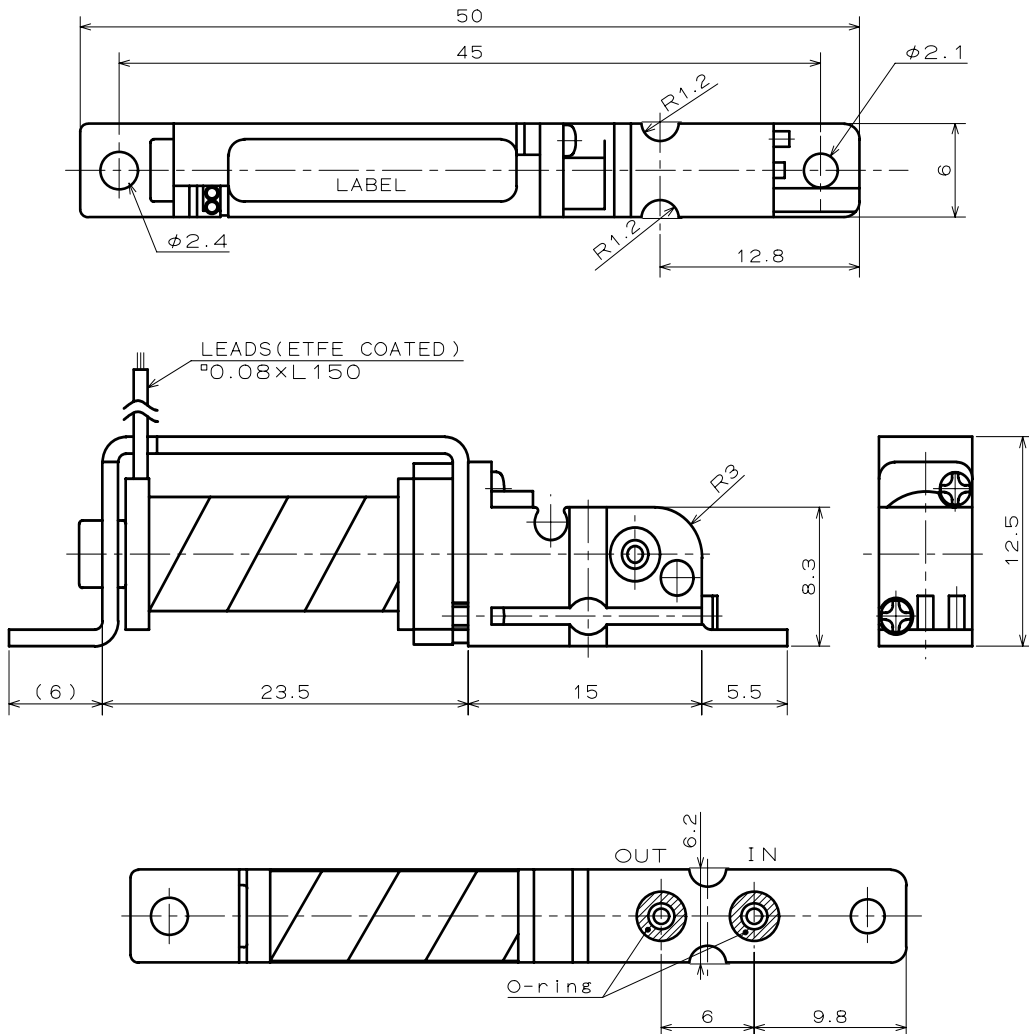

Example of Manifold Configuration

3-valve manifold clamped by screws

